



杰创·东方  
JCDOFAMA



## 连续退火铜线中拉机

### Medium Copper Wire Drawing Machine with Annealer



- ◆ 水平全浸水式四组多级拉线轮，可换式钨钢圈或陶瓷圈  
Fully immersing horizontal slip type four capstan with multi-step replaceable tungsten carbide ring or alumina cone
- ◆ 高性能精密斜齿轮传动，强供油润滑系统，高效率，低噪音  
A helical gear transmission are enforced lubricant of high efficiency with low noise
- ◆ 退火机为立式二段式连续直流退火，无需蒸气保护  
A vertical resistance annealer by DC in 2 section, no steam required
- ◆ 本机可选配连续退火机，单盘收线机或成圈下线机  
On-line continuous annealer, single spooler or basket down coiler are available
- ◆ 电脑控制拉线与退火同步，退火铜线延伸率均匀，无废线  
Microcomputer control of drawing and annealing speed synchronization, equalizing wire soft and eliminating hard wire scrap



IAF & PAC 多边认可  
协议集团成员认可  
ACCREDITED BY IAF & PAC  
MLA GROUP MEMBER

## 连续退火铜线中拉机

### Medium Copper Wire Drawing Machine with Annealer

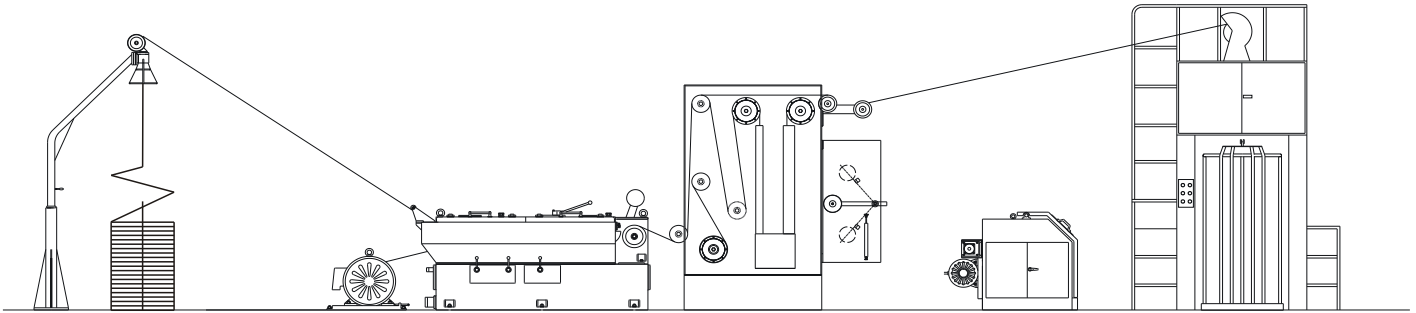

#### 技术参数 Technical Data

名称 Description	参数 Specification
进线直径(Inlet wire dia.)	3.0-3.5mm
出线直径(Outlet wire dia.)	0.4 - 2.8 mm
出线速度(linear speed)	3 - 25 m/s (二档机械速度,无级调速)
最多拉伸道次(Max. drawing pass)	17
定速轮直径(Finish capstan dia.)	250 mm
主电机(Main motor)	45 kW
退火线径(Annealing wire dia.)	0.4-2.8 mm
最大退火速度(Max. annealing speed)	25 m/s
最大退火电压(Max. annealing voltage)	50 V
最大退火电流(Max. annealing current)	2500 A
退火轮直径(Annealing wheel dia.)	250 mm
压缩空气用量	200L/min (0.6-0.7MPa)
最大收线速度(Max. take-up speed)	25 m/s
收线电机(Take-up motor)	11 kW
收线盘规格(Take-up bobbins)	PND400-630 (DIN46397)
成圈收线筒尺寸(basket size)	Φ800×Φ500×1450mm
设备总重量(Total weight)	12000 Kg
设备总尺寸(Overall dimension)	14000×2300×2700 mm



主机  
Drawing machine



退火装置  
Annealer

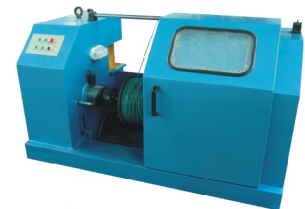

单盘收线机  
Single spooler

★ 参数更改恕不通知 Technical modification reserved



德阳杰创线缆机械有限责任公司

Deyang Jiechuang Wire & Cable Machinery Co., Ltd.

德阳东方电工控制设备有限公司

Deyang Dongfang Electrotechnical Control Equipment Co., Ltd.

中国·四川·德阳市天元开发区太华山路北段(邮编: 618000)

Taihuashan Road North, Tianyuan Industrial Area, Deyang, Sichuan 618000, China

电话(Tel): +86-838-2802628, 2823685 传真(Fax): +86-838-2800877

Website: www.jcdofama.com

e-mail: jcdofama@163.com